

**Small & Large Area Photodiodes
Two-Color Photodiodes
TE Cooled Photodiodes**

Ge Photodiodes



- **Large and Small Area**
- **Wide Performance Range**
- **TE Coolers and Two-Color Sandwich**
- **Filtered Windows for High Power Available**
- **Standard and Custom Packages/Submounts**

GPD Optoelectronics Corp

7 Manor Parkway
Salem, NH 03079 U.S.A.
Tel/Fax: (603)894-6865/6866
<http://www.gpd-ir.com>



Introduction

GPD Optoelectronics manufactures a broad range of Ge and InGaAs photodetectors to meet the most demanding military and commercial applications. This brochure contains technical specifications for Ge, dual (Si/Ge) detectors, and TE cooled Ge photodiodes.

Custom devices and packages are also available.

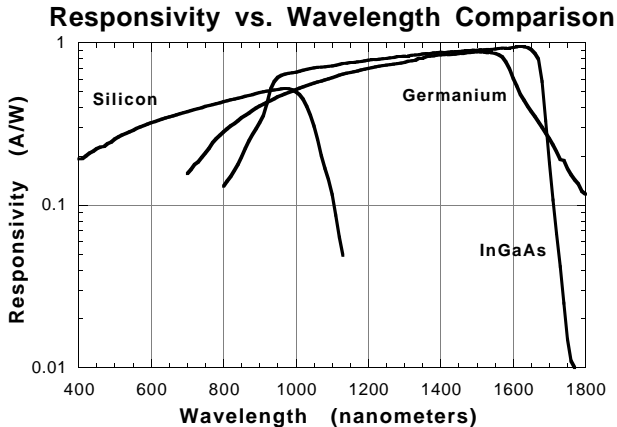

Both Germanium and InGaAs are sensitive to light in the near-infrared region of the spectrum. While InGaAs detectors offer better noise performance, Ge detectors offer better linearity and cost advantages, particularly where a large detection area is required.

Table of Contents

Glossary of Terms	2
Operating Circuits	3
Ge pn Detectors	4-5
Two-color Detector	6
Package Outline Drawings	7-12

Glossary of Terms

DARK CURRENT (I_D)

The current through a photodetector when a specified reverse bias is applied under conditions of no incident radiation.

SHUNT RESISTANCE (R_{SH})

The resistance of a photodetector at or near zero bias; shunt resistance values in this catalog are calculated at 10mV reverse bias.

MAXIMUM REVERSE VOLTAGE (V_{RM})

The maximum reverse voltage that may be applied without damaging the detector.

RESPONSIVITY (R)

The photocurrent output per unit incident radiant power, usually at a specified wavelength.

NOISE EQUIVALENT POWER (NEP)

The incident radiant power that creates a signal-to-noise ratio of one at the photodetector output.

JUNCTION CAPACITANCE (C_J)

The total device capacitance, usually measured at a specified reverse bias and frequency.

CUTOFF FREQUENCY (f_c)

The frequency at which the responsivity decreases by 3 dB from the DC responsivity value. It can be calculated from the load resistance and the junction capacitance. $f_c = 1/(2\pi R_L C_J)$

GPD Optoelectronics Corp

7 Manor Parkway

Salem, NH 03079 U.S.A.

Tel/Fax: (603)894-6865/6866

<http://www.gpd-ir.com>



**BASIC OPERATING CIRCUIT
(ZERO BIAS)**

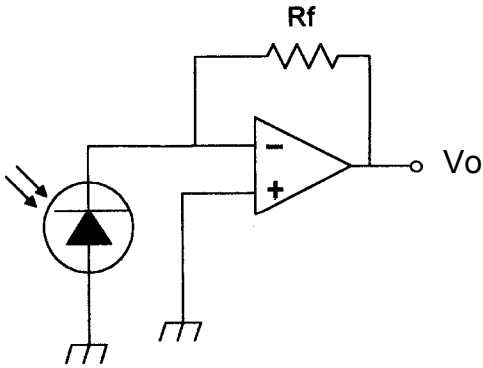

**BASIC OPERATING CIRCUIT
(WITH BIAS)**

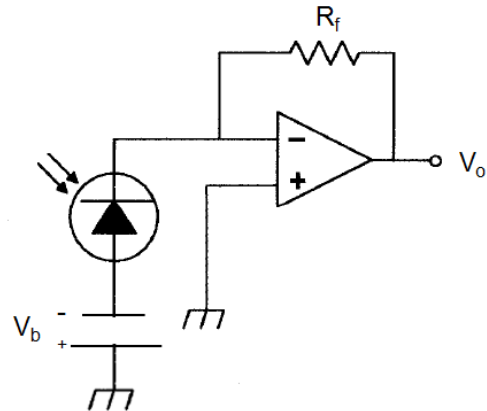

HIGH SPEED CIRCUIT

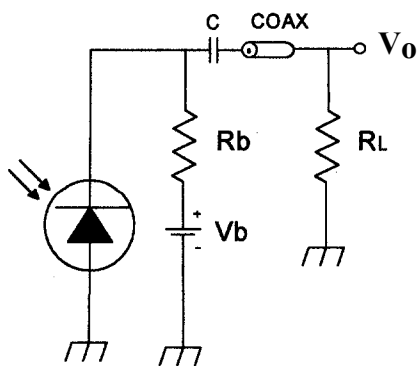

EQUIVALENT CIRCUIT

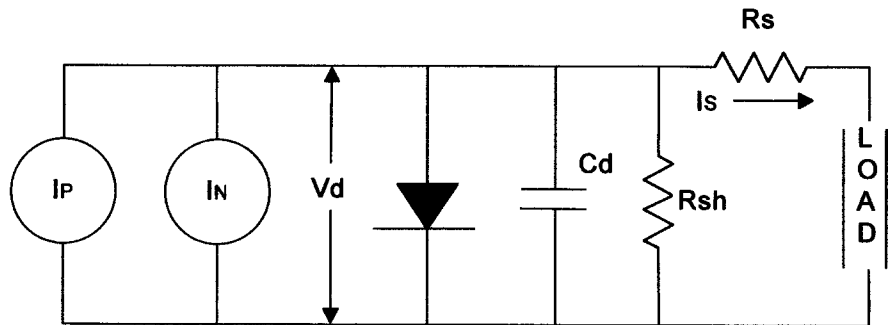

I_p : Photocurrent

I_N : Noise Current

V_D : Voltage across diode

V_b : Bias Voltage

I_s : Output Current

C_d : Photodiode Capacitance

R_{sh} : Shunt Resistance

R_s : Series Resistance

R_f : Feedback Resistance

V_o : Output Voltage ($I_s \times R_f$)

GPD Optoelectronics Corp

7 Manor Parkway

Salem, NH 03079 U.S.A.

Tel/Fax: (603)894-6865/6866

<http://www.gpd-ir.com>



Ge Photodiodes TE Cooled Photodiodes

TYPE	ACTIVE DIA. (mm.)	SHUNT RES. @ $V_r=10\text{mV}$ (K Ω)		DARK CURRENT @ $V_r=V_{\text{test}}$ (μA MAX)	TEST REVERSE BIAS (Volts)	MAX REVERSE VOLTS	CAPACITANCE @ V_r MAX (pF)	NEP (pW/ $\sqrt{\text{Hz}}$)	CUT-OFF FREQ. @ V_r , $50\Omega R_L$ (MHz)
		MIN.	TYP.						
GM2 GM2HS GM2VHS GM2VHR	0.5 SQ	30	60	2.0	10	15	27	1.0	120
		100	150	1.0	3.0	5.0	110	0.3	30
		250	350	0.7	0.3	0.5	300	0.2	10
		550	900	0.5	0.3	0.5	300	0.1	10
GM3 GM3HS GM3VHS GM3VHR	0.1	120	180	1.0	10	15	1	0.3	3000
		350	500	0.3	3.0	5.0	6	0.1	500
		1500	2500	0.1	0.3	0.5	21	0.1	150
		2000	3000	0.1	0.3	0.5	21	0.1	150
GM4 GM4HS GM4VHS GM4VHR	0.3	60	80	1.5	10	15	10	0.6	300
		250	400	0.4	3.0	5.0	50	0.3	60
		400	650	0.2	0.3	0.5	200	0.2	16
		900	1600	0.2	0.3	0.5	200	0.15	16
GM5 GM5HS GM5VHS GM5VHR	1.0	20	40	3.0	10	15	85	1.5	35
		60	100	1.5	2.0	3.0	300	0.5	10
		200	280	0.5	0.3	0.5	1450	0.3	2.0
		330	450	0.5	0.3	0.5	1450	0.3	2.0
GM6 GM6HS GM6VHS GM6VHR	2.0	6	12	10	10	15	300	2.0	17
		30	60	3.0	2.0	3.0	1200	0.8	1.0
		80	120	1.0	0.3	0.5	9000	0.4	0.6
		120	200	1.0	0.3	0.5	9000	0.4	0.6
GM7 GM7HS GM7VHS GM7VHR	3.0	4	8	30	5.0	10	800	3.0	4.0
		25	35	4.0	1.0	3.0	4000	1.0	0.7
		40	65	3.0	0.25	0.5	13000	0.6	0.2
		65	90	2.0	0.25	0.5	13000	0.6	0.2
GM8 GM8HS GM8VHS GM8VHR	5.0	2	4	40	3.0	5.0	3000	4.0	1.6
		10	15	15	1.0	3.0	6000	2.0	0.5
		15	20	5	0.1	0.3	35000	1.0	0.1
		20	30	5	0.1	0.3	35000	1.0	0.1
GM10HS	10 SQ.	2.0	3.5	50	0.5	1.0	30000	4.0	0.1
GM13HS	13	1.0	2.0	100	0.5	1.0	50000	8.0	0.05
GM5TEC1	1.0		300	0.2	5.0	7.0	85	0.4	55
GM8TEC2	5.0		60	1.0	1.0	2.0	3000	1.0	1.6

VHS series: Designed for zero reverse bias applications requiring high shunt resistance.
VHR series: Designed for zero reverse bias applications.
HS series: Designed for < 5V reverse bias applications.
GM series: Designed for high speed applications with reverse bias > 10V.
TEC series: Mounted on a one- or two-stage thermoelectric cooler for low-noise applications.

GPD Optoelectronics Corp

7 Manor Parkway

Salem, NH 03079 U.S.A.

Tel/Fax: (603)894-6865/6866

<http://www.gpd-ir.com>



Electrical Specifications

Dark Current vs. Reverse Bias

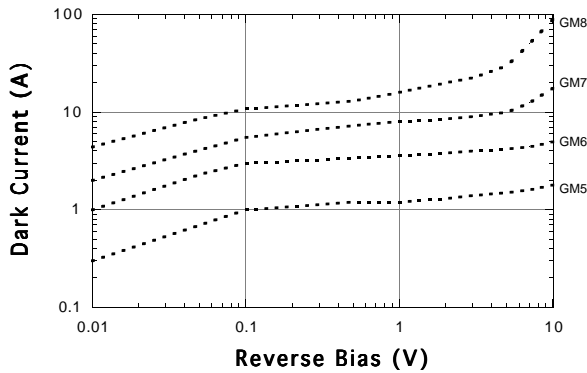

Linearity of Response

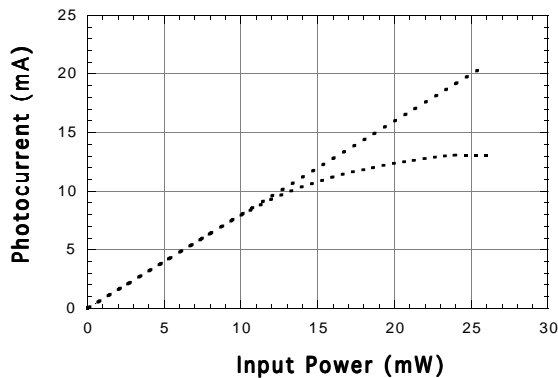

Shunt Resistance vs. Temperature

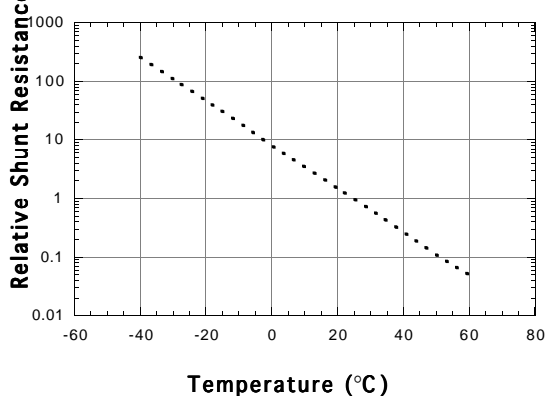

Optical Specifications

Responsivity vs. Wavelength

Series	WAVELENGTH					
	850		1300		1550	
	min.	typ.	min.	typ.	min.	typ.
GM	.20	.26	.60	.65	.75	.85
GMHS	.20	.26	.60	.70	.75	.85
GMVHS	.20	.26	.60	.70	.80	.85
GMVHR	.26	.32	.70	.80	.82	.87

Uniformity of Response

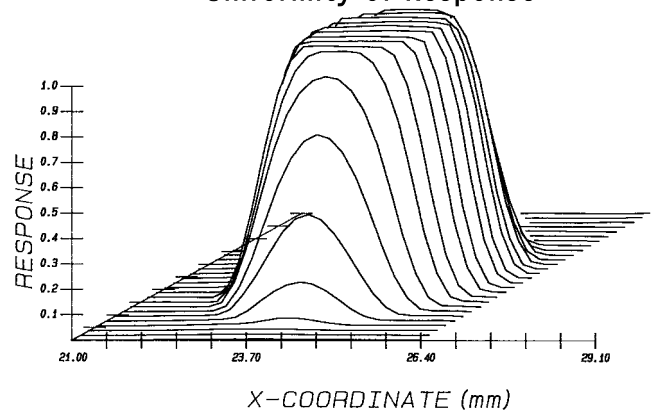

Responsivity of Filtered Units

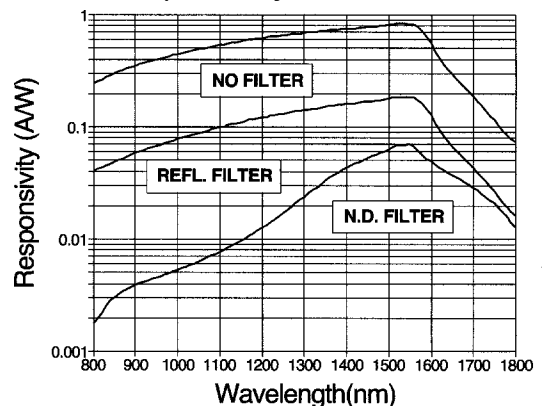

GPD Optoelectronics Corp

7 Manor Parkway
 Salem, NH 03079 U.S.A.
 Tel/Fax: (603)894-6865/6866
<http://www.gpd-ir.com>



Two-Color Photodiodes

Capacitance vs. Reverse Bias

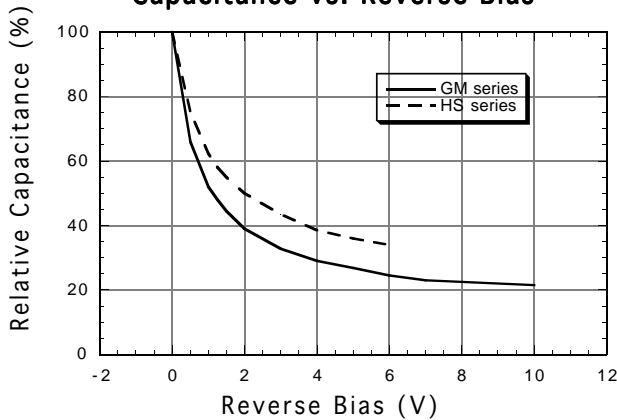

Special Options

- High response at short wavelength available
- BNC connectors
- Thermoelectric coolers (1- and 2-stage)
- Neutral density filters
- Bandpass Filters
- AR-coated lenses/windows
- Custom devices including arrays
- Calibrated spectral response

Si/Ge TWO-COLOR DETECTOR: ELECTRICAL SPECIFICATIONS

Type	Active Diam. (mm)	Wavelength Range (nm)	Peak Resp. (A/W)	NEP (pW/ $\sqrt{\text{Hz}}$)	R_{SHUNT} (K Ω)	Max Reverse Volts (V)	Leakage Current	Forward Voltage (V) $I_{\text{PH}}=10\text{mA}$
(Si) GM6Si5	5	400-1000	0.5	1.0×10^{-14}	> 1000	30	2 nA	1.1
(Ge)	2	1000-1800	0.6	1.0×10^{-12}	60	3	2 μA	0.45
(Si) GM7Si5	5	400-1000	0.5	1.0×10^{-14}	> 1000	30	2 nA	1.1
(Ge)	3	1000-1800	0.6	1.5×10^{-12}	25	3	3 μA	0.45
(Si) GM8Si5	5	400-1000	0.5	1.0×10^{-14}	> 1000	30	2 nA	1.1
(Ge)	5	1000-1800	0.6	2.0×10^{-12}	10	1.5	10 μA	0.45

GPD Optoelectronics Corp

7 Manor Parkway

Salem, NH 03079 U.S.A.

Tel/Fax: (603)894-6865/6866

<http://www.gpd-ir.com>



Package Drawings

Dimensions in mm (in.) Many other packages (including lensed packages) available.

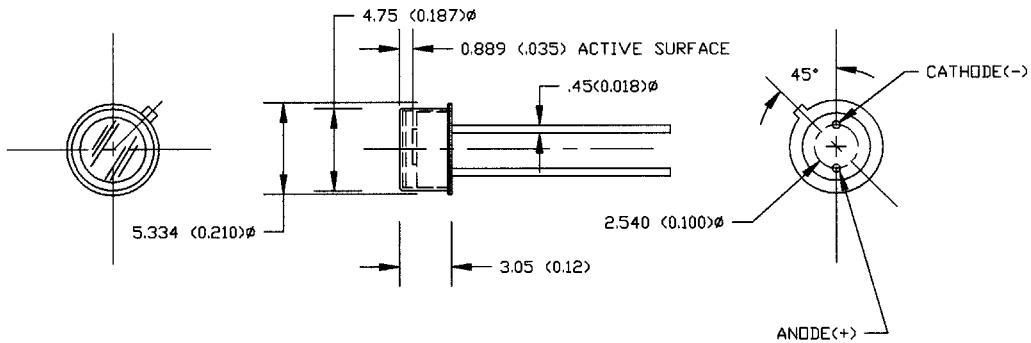

TO-18
(Chip Diameter to 2 mm)

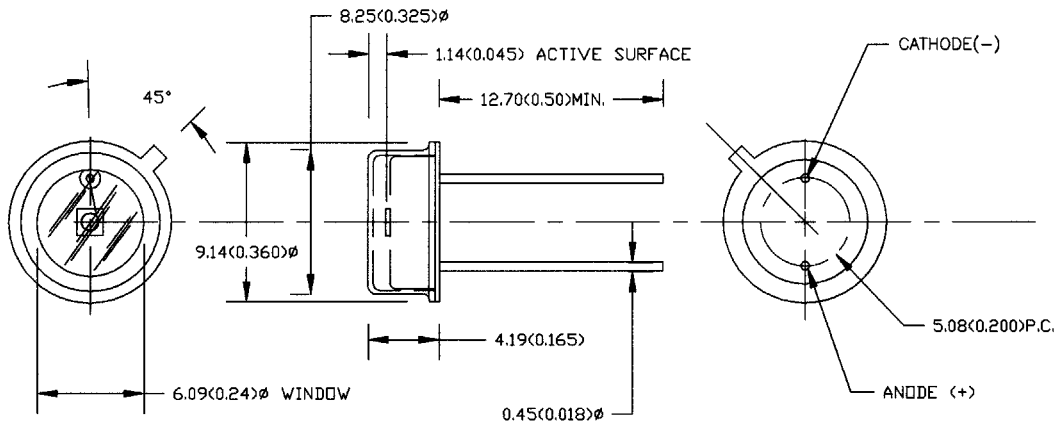

TO-5
(Chip Diameter to 3 mm)

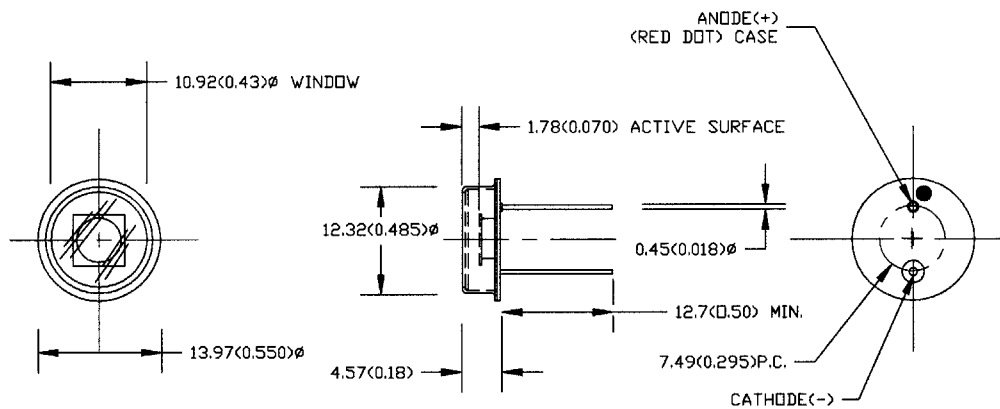

TO-8 (5 mm chip)

GPD Optoelectronics Corp

7 Manor Parkway

Salem, NH 03079 U.S.A.

Tel/Fax: (603)894-6865/6866

<http://www.gpd-ir.com>



Package Drawings

Dimensions in mm (in.) Many other packages (including lensed packages) available.

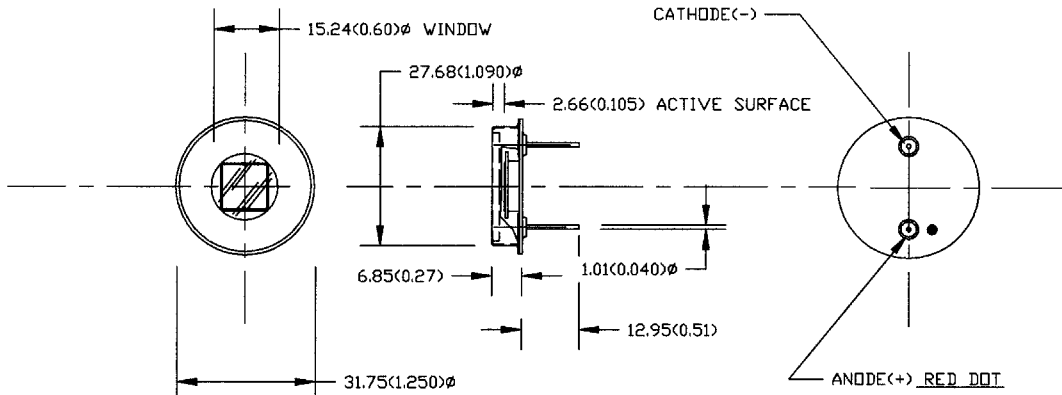

TO-9
(Chip Diameter to 13 mm)

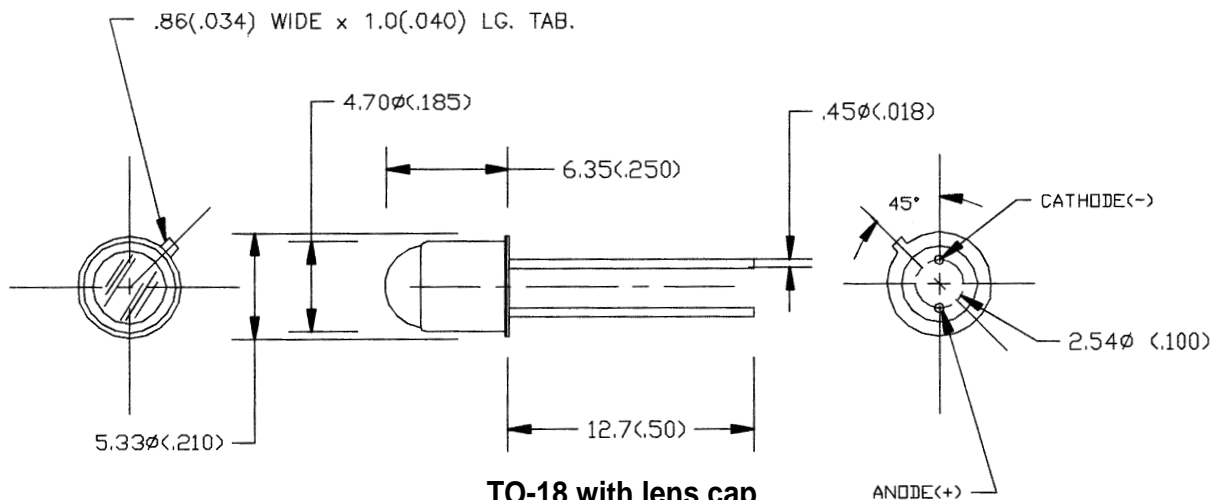

TO-18 with lens cap
(Chip Diameter to 2 mm)

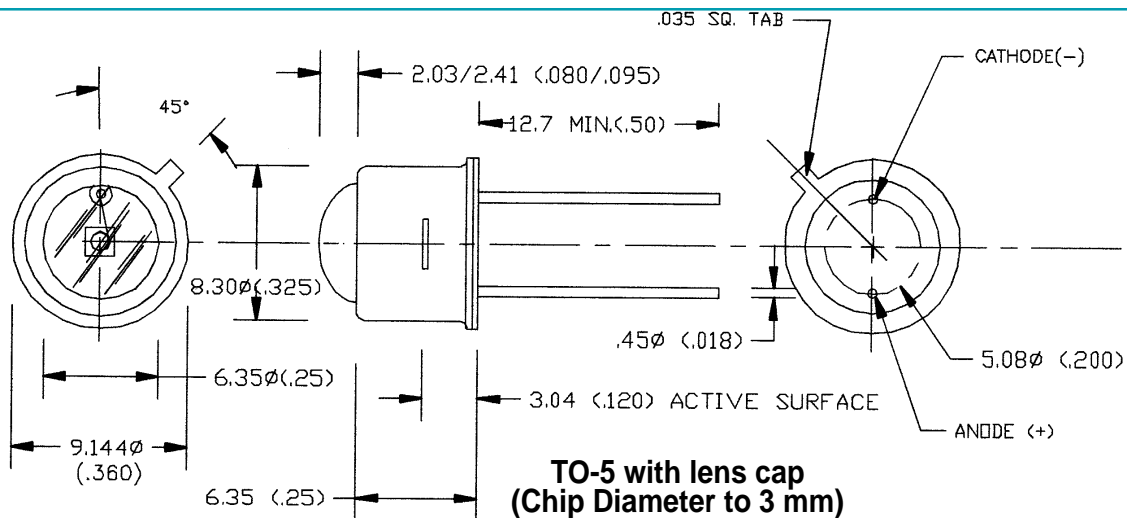

TO-5 with lens cap
(Chip Diameter to 3 mm)

GPD Optoelectronics Corp

7 Manor Parkway
Salem, NH 03079 U.S.A.
Tel/Fax: (603)894-6865/6866
<http://www.gpd-ir.com>



Package Drawings

Dimensions in mm (in.) Many other packages (including lensed packages) available.

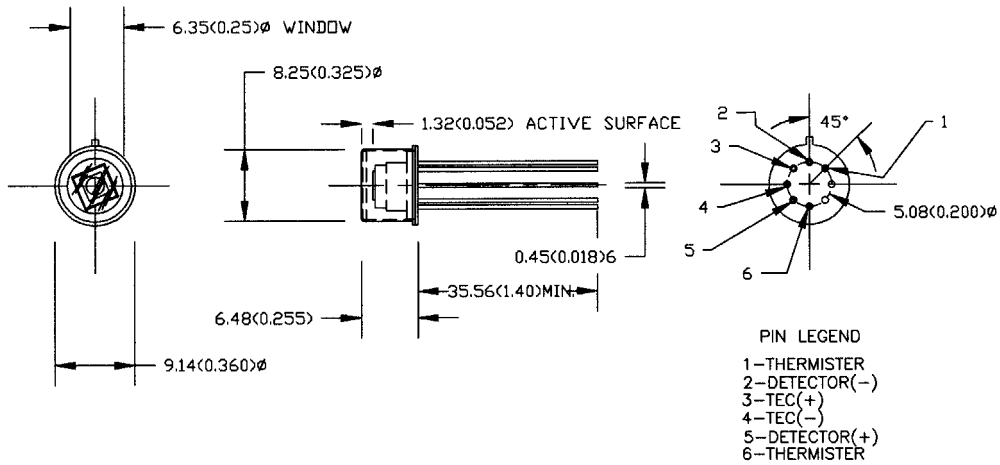

**TO-5 with TEC
(Chip Diameter to 3 mm)**

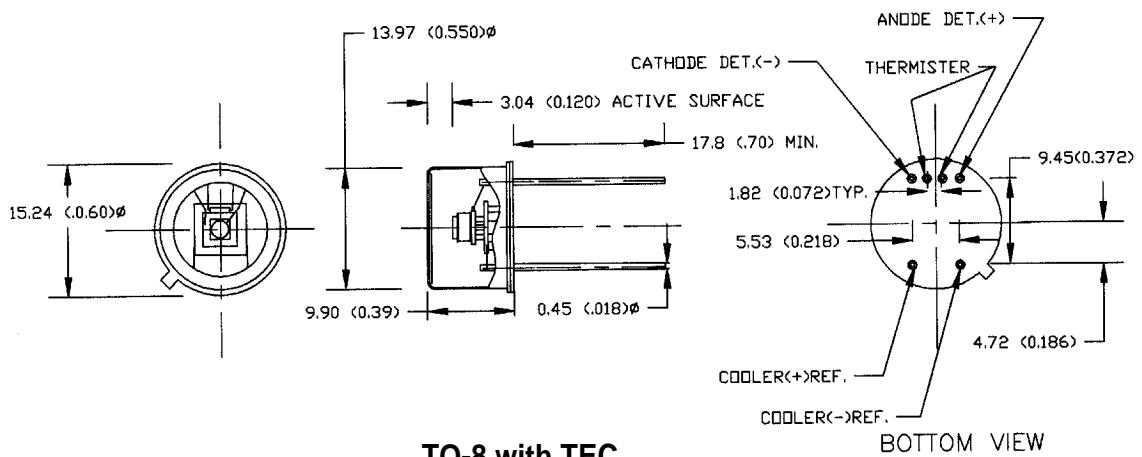

**TO-8 with TEC
(Chip Diameter to 5 mm)**

GPD Optoelectronics Corp

7 Manor Parkway
Salem, NH 03079 U.S.A.
Tel/Fax: (603)894-6865/6866
<http://www.gpd-ir.com>



Package Drawings

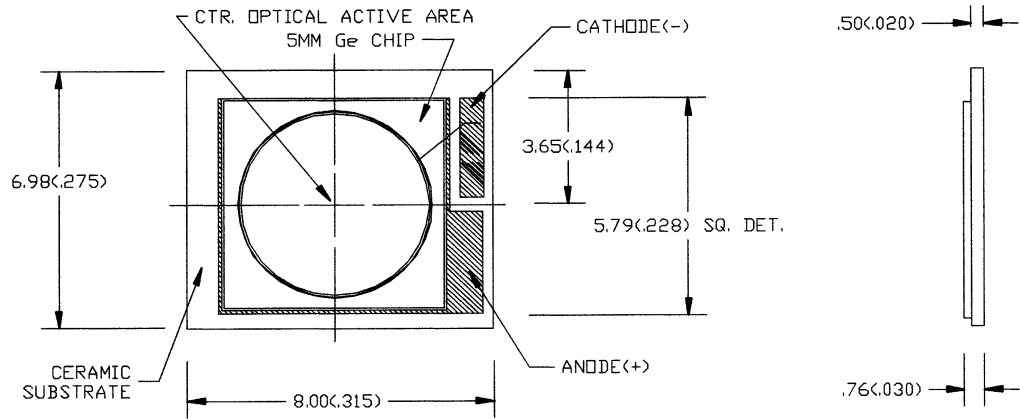

GM8HSCS

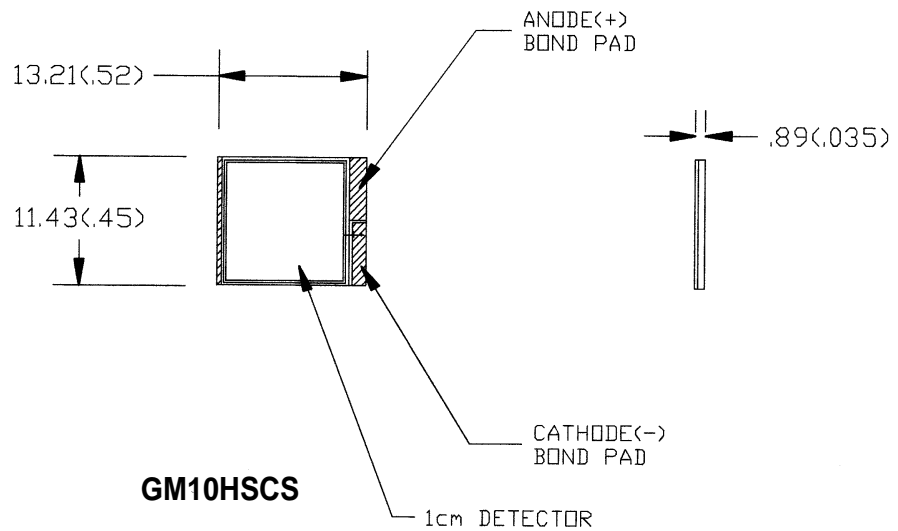

GM10HSCS

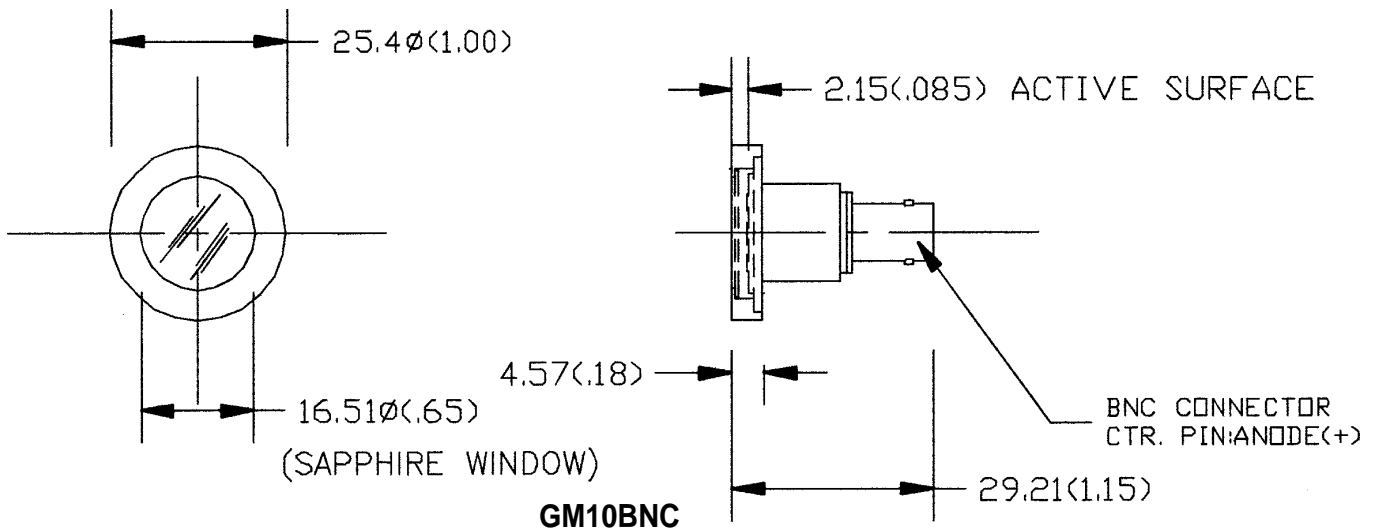

GM10BNC

GPD Optoelectronics Corp

7 Manor Parkway

Salem, NH 03079 U.S.A.

Tel/Fax: (603)894-6865/6866

<http://www.gpd-ir.com>



Package Drawings

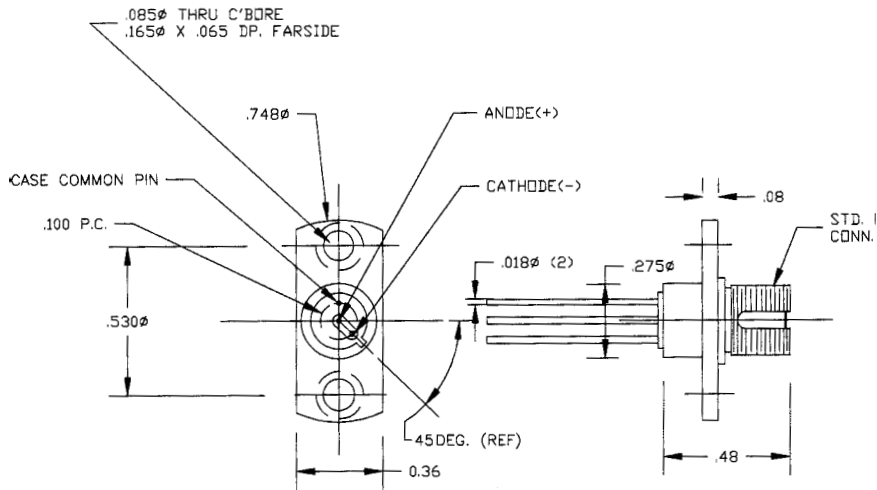

FC Active Mount

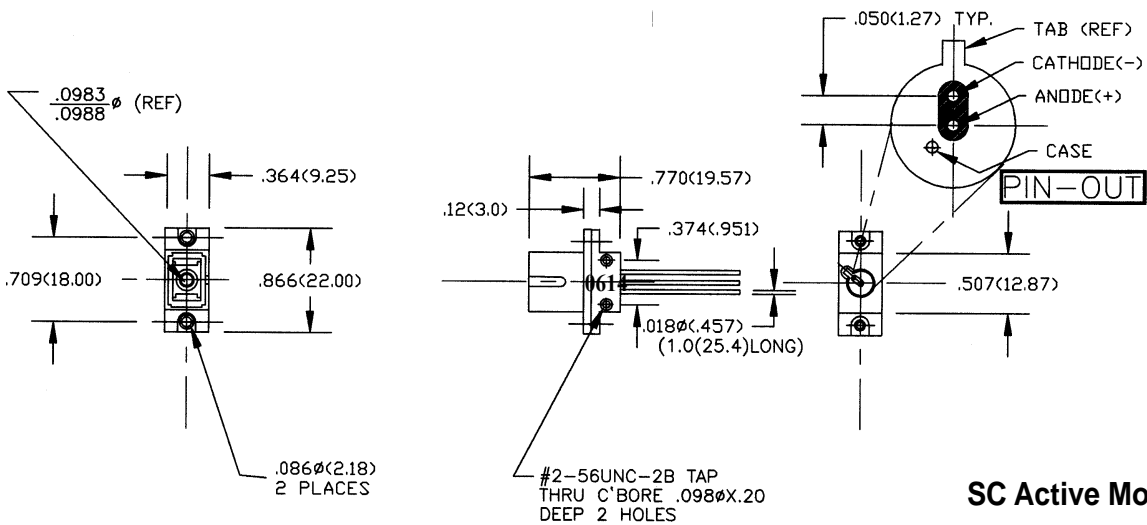

SC Active Mount

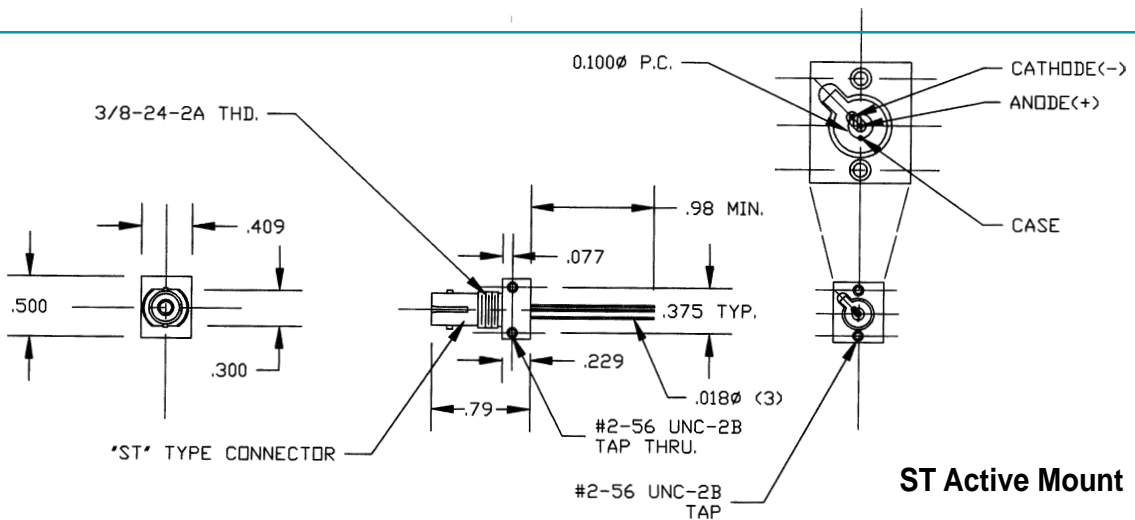

ST Active Mount

GPD Optoelectronics Corp

7 Manor Parkway
Salem, NH 03079 U.S.A.
Tel/Fax: (603)894-6865/6866
<http://www.gpd-ir.com>



Dimensions in mm (in.) Many other packages (including lensed packages) available.

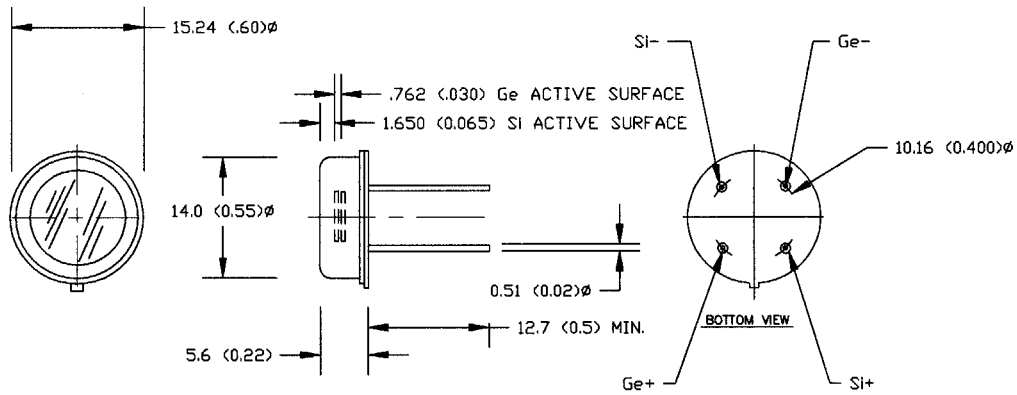

Si/Ge Two-color Detector

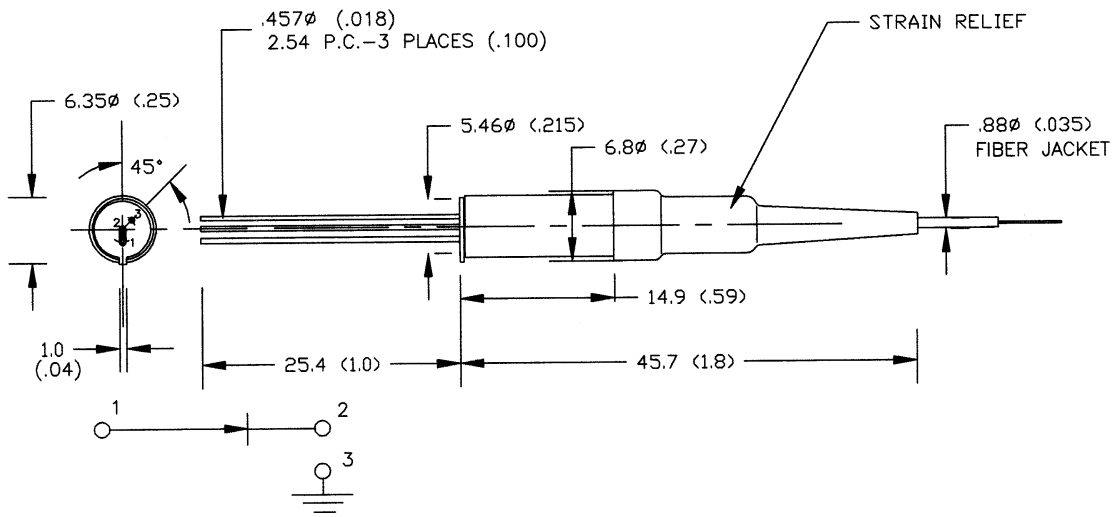

Fiber-pigtailed Detector

GPD Optoelectronics Corp

7 Manor Parkway

Salem, NH 03079 U.S.A.

Tel/Fax: (603)894-6865/6866

<http://www.gpd-ir.com>